



## INSTALLATION INSTRUCTIONS

### SUZUKI Z400

### NERF BAR

To avoid injury to yourself or damage to vehicle, read these instructions before installation.

#### 1) Parts:

| Item | Part Name                        | Description                            | Qty |
|------|----------------------------------|--|-----|
| 1    | Nerf Bar                         | Left Side (with welded tube)           | 1   |
| 2    | Nerf Bar                         | Right Side                             | 1   |
| 3    | Head Bolt M10 X 1.25 X 80mm Long | Attach Front Nerf Bar to A-Arm Support | 2   |
| 4    | Head Bolt M8 X 1.25 X 20mm Long  | Attach Rear Nerf Bar to Foot Peg       | 4   |
| 5    | Nylock Nut M8 x 1.25             | Attach Rear Nerf Bar to Foot Peg       | 4   |
| 6    | Web Set                          | (1) Left & (1) Right                   | 1   |
| 7    | Frame Web Clip                   | Attach web netting to ATV Frame        | 4   |
| 8    | Flat Washer                      | M10                                    | 2   |
| 9    | Flat Washer                      | M8                                     | 8   |

#### 1) Remove Front Left & Right OEM Bolts in A-Frame Bushings.

**NOTE: You may discard the (2) OEM Bolts but retain the (2) OEM Nuts.**

#### 2) Attach Left & Right Front Nerf Bars

a) Insert (2) Item #3 Bolts and #8 Washers through Front A-Frame Bushings and through Front Nerf Bar Tab hole until "flush" with tab.

b) Loosely install "Front" Left & Right Nerf Bars by inserting Left Nerf Bar Tube into Right Nerf Bar Tube.

**NOTE: Align Nerf Bar Tab holes with Front A-Arm Bushing bolts and then push bolts through Nerf Bar tab holes.**

c) Loosely attach Front Nerf Bars to the Item #3 bolts using (2) OEM Nuts saved in Step 1.

#### 3) Attach Rear Nerf Bar

a) Loosely attach Left & Right Rear Nerf Bar Brackets to OEM Foot Pegs using (4) Item #4 Bolts, (8) Item #9 Washers and (4) Item #5 Nuts.

**NOTE: Depending on model bike or after market foot pegs, you may be required to "match" drill 8mm diameter holes in your foot pegs to attach hardware item's # 4 & 5**

4) When Left & Right Nerf Bars are positioned correctly torque as follows:

M10 Bolts @ 60Nm / 44 ft. lbs.

M8 Bolts @ 30Nm / 22.2 ft. lbs.

5) Install Webbing to Nerf Bar:

a) Install Web Straps on Welded Tabs of Nerf Bar: see Fig. #2

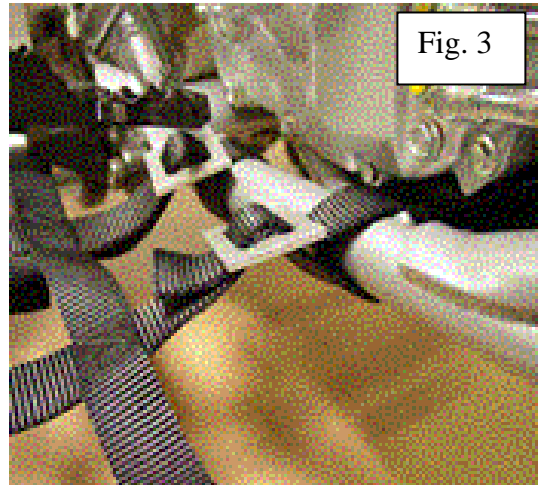

6) Be sure to secure Web Set frame straps around ATV lower frame using Frame Web Clips (Item #7): see Fig. #3



6. **Customer service:** For further information call Pro Armor at 951-270-0559

|  |
|--|
|  <b>WARNING</b>  |
| If nerf bar webbing is torn or damaged in any way, immediately stop riding the vehicle and replace the webbing. Do not operate the vehicle without securely installing the webbing to the vehicle frame. |

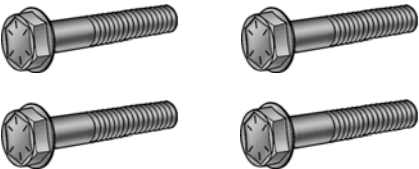
# S031088

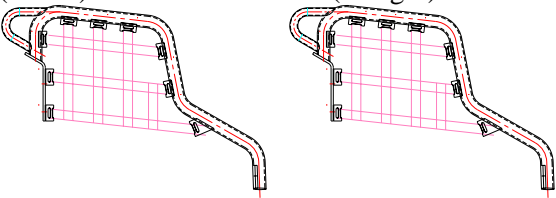
|        |  |  |   |
|--------|--|--|---|
| ·<br>2 | <b><u>M10</u></b> X 1.25 X <b><u>80mm</u></b> Bolt Gr 10.9 | Hex Head Flange Bolt<br>                     | 2 |
| ·<br>3 | <b><u>M8</u></b> X 1.25 X <b><u>20mm</u></b> Bolt Gr 10.9  | Hex Head Flange Bolt<br>                     | 4 |
| ·<br>4 | <b><u>M8</u></b> X 1.25 Nylock Nut                         | Nut<br>                                      | 4 |
| ·<br>5 | Web Set  | (1 Left)                      (1 Right)<br> | 1 |

-----  
SIGNATURE OF KIT ASSEMBLER

-----  
DATE